

TECHNICAL DATA	UNIT.	PRE-U		PRE-CP	
GENERAL DETAILS		WITH BOILER	WITHOUT BOILER	WITH BOILER	WITHOUT BOILER
Board dimensions	mm	1.170 x 360 x 220	1.170 x 360 x 220	940 x 160	940 x 160
Boiler capacity	l	16	-	16	-
Compressor	-	Opt	Opt	Opt	Opt
Group of Iron	-	Opt	Opt	Opt	Opt
Steam gun	-	Opt	Opt	Opt	Opt
Polished upper buck	-	Opt	Opt	Opt	Opt
POWER					
Vacuum Motor	HP	0,6	0,6	0,6	0,6
Pump Motor	HP	0,75	-	0,75	-
Compressor motor (Mod. with option)	HP	2	2	2	2
Boiler Heater	kW	12	-	12	-
CONNECTIONS					
Ø Water inlet	BSP	3/8"	-	3/8"	-
Ø Boiler exhaust (mod. with boiler)	BSP	1/2"	-	1/2"	-
Ø Steam inlet	BSP	-	1/2"	-	1/2"
Ø Condensate outlet	BSP	-	1/2"	-	1/2"
Steam pressure	BAR	4-5	4-5	4-5	4-5
Steam Consumption	Kg/h	12-20	12-20	12-20	12-20
Ø Air inlet	BSP	-	3/8"	-	3/8"
Ø Air pressure	BAR	6-7	6-7	6-7	6-7
Ø Air Consumption	NI/m	40	40	40	40
DIMENSIONS / PACKING DIMENSIONS					
Width / Width	mm	1.370/1.440	1.370/1.440	1.370/1.440	1.370/1.440
Depth / Depth	mm	1.080/1.110	1.080/1.110	1.080/1.110	1.080/1.110
Height / Height	mm	1.250/1.410	1.250/1.410	1.250/1.410	1.250/1.410
Net weight / Gross weight	kg	292/342	237/287	292/342	237/287
Gross volume	m ³	2,25	2,25	2,25	2,25
OTHER					
Voltage	Hz	230/400V III 50/60Hz	230/400V III 50/60Hz	230/400V III 50/60Hz	230/400V III 50/60Hz
Sound level	dB	70	70	70	70

PUN-C / PUN-C C & P
WITH BOILER (AUTONOMOUS)

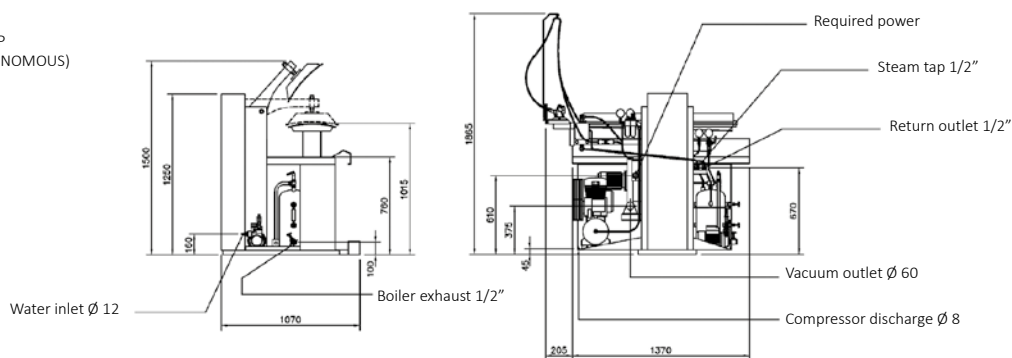

PUN-C / PUN-C C & P
WITHOUT BOILER

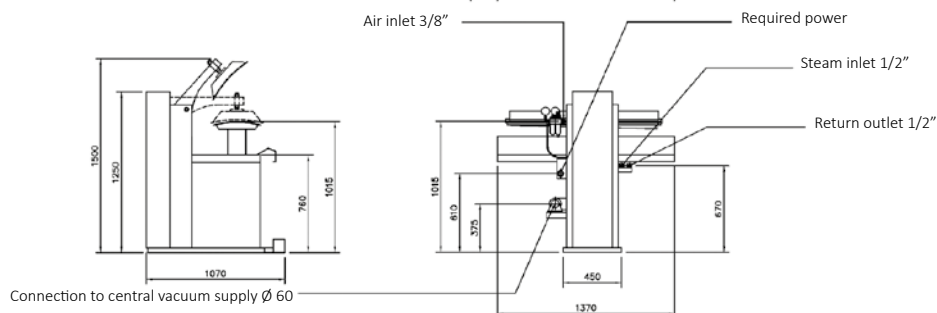

While every effort has been made to ensure the information provided is accurate, MAG Equipment Ltd accepts no liability whatsoever for any errors, inaccuracies or omissions and shall not be bound in any manner by any information provided.