

TECHNICAL DATA	UNIT.	LS-11 T	LS-14 T	LS-19 T
DRUM				
Load capacity 1:9 / 1:10	Kg	11/10	14/13	20/18
Volume	l	100	130	180
Diameter	mm	532	620	700
Depth	mm	425	430	470

GENERAL DETAILS				
Washing speed / Spining speed	r.p.m.	50/ 1.245	50/ 1.150	47/ 1.080
G Factor	-	450	450	450
Maximum force transmitted	KN	2,3 ±0,2	2,5 ±1,05	3,6 ±1,4
Frequency-dynamic force	Hz	16,7	16,7	16
Sound level	dB	70	70	70
Self-service version	-	Yes	Yes	Yes
Double drain	-	No	Opc	Opt
Weighing System / Tilting System	-	Opt/No	Opt/No	Opt/No

DOOR				
Height center door / Height door	mm	625/415	700/440	750/510
Diameter	mm	290	373	373

POWER				
Motor	kW	0,75	1,5	2,2
Heating (Electric model)	kW	6	9	12
Max. power (Electric model)	kW	6,25	9,5	12,75
Max. power (steam and hot water)	kW	0,75	1,5	2,2

CONNECTIONS		ELECTRICAL	VAPOR / AGUA CAL.	ELECTRICAL	VAPOR / AGUA CAL.	ELECTRICAL	VAPOR / AGUA CAL.
Tension 230V- I + N + T	Nº x mm2 / A	3 x 4 / 32A	3 x 1,5 / 6A	3 x 10 / 50A	3 x 1,5 / 10A	3 x 16 / 63A	3 x 1,5 / 10A
Tension 230V- III + T	Nº x mm2 / A	3 x 2,5 / 20A	-	3 x 4 / 25A	-	3 x 6 / 40A	-
Tension 400V- III + N + T	Nº x mm2 / A	3 x 1,5 / 10A	-	3 x 1,5 / 16A	-	3 x 2,5 / 20A	-
Steam inlet (Steam mod.)	inch	1/2"		1/2"		1/2"	
Maximum steam consumption (Steam mod.)	Kg/h	7		8,5		12	
Water inlet	inch	3/4"		3/4"		3/4"	
Water main pressure	Kgs/cm ²	2-4		2-4		2-4	
Maximum water consumption*	Lit/h	71,4		88,8		118,3	
Drain	mm/inch	3"		3"		3"	
Drainage capacity	Lit/min	200		200		200	

DIMENSIONS / PACKING DIMENSIONS				
Width / Width	mm	692/730	788/830	884/930
Depth / Depth	mm	788/1.000	870/1.010	914/1.030
Height / Height	mm	1.158/1.410	1.301/1.560	1.409/1.700
Net weight / Gross weight	kg	230/239	250/283	360/393
Volume	m ³	1,03	1,31	1,63

* Nº20 Program, 75% load

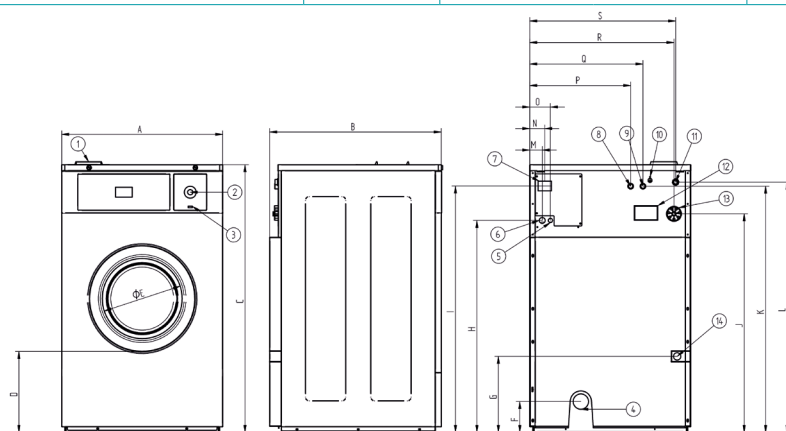

01. Soap dispenser
02. Emergency stop
03. Usb port
04. Drain
05. Electric connection to liquid soap pumps
06. Electrical connection
07. Main switch
08. Auxiliar water inlet
09. Hot water inlet
10. Ground connection
11. Cold water inlet
12. Blur output / water overload
13. Liquid soap connection
14. Steam connection

	A	B	C	D	E	F	G	H	I	J	K	L	M	N	O	P	Q	R	S
LS-11 T	692	788	1.158	408	290	93	355	886	1.055	940	1.053	1.073	61	74	101	413	468	610	623
LS-14 T	788	869	1.307	427	373	130	385	1.035	1.203	1.067	1.202	1.222	61	74	101	494	554	706	714
LS-19 T	884	913	1.415	490	373	99	390	1.143	1.207	1.166	1.331	1.331	61	74	101	437	517	769	810